

SPECIFICATION FOR BLUE LED

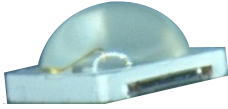

LML-LK-BZ-0.5W

- Serial Number : LML-LM-BZ-0.5W-Run No-Bin No-L1.9T
- 0.5W maximum power capability
- Lead-free reflow soldering application
- Built-in ESD protection device
- RoHS compliant

LUMENS

Vendor		Customer
Written	Approval	Approval

Lumens CO., LTD.

456 Gomae-Dong, Giheung-Gu, Yongin-Si, Gyeonggi-Do 449-901 Korea

<http://www.lumens.co.kr>

1. Product description

* Description

- The LK series LED is designed for the high power operation to get the high flux output applications.
- It incorporates the state of the art SMD design and high reliable material.
- It is ideal for the light source for general illumination applications, custom designed solutions.

* Features

- Maximum drive current up to 150mA
- Low thermal resistance as low as 12°C/W
- Wide viewing angle of 120~140 degrees
- Reflow soldering with JEDEC JSTD-020C compatible
- RoHS compliant

* Applications

- General luminaire
- Bulb
- Downlight

2. Absolute maximum ratings

Parameters	Symbol	Min Value	Max Value	Unit
Power dissipated	Pd		0.46	W
Rated forward current	If		150	mA
Allowable peak forward current(1)	Ip		200	mA
Maximum junction temperature capability	Tj		110	°C
Electrostatic discharge threshold(2)	ESD		±5,000	V
Operating temperature	Top	-40	+85	°C
Storage temperature	Tst	-40	+85	°C
Soldering temperature(Reflow)	Tsor		260°C, 10s	°C, s
Soldering temperature(Hand)	Tsoh		350°C, 3s	°C, s

(1) Ip measured at 1/10 duty cycle, 0.1ms pulse width.

(2) ESD HBM class 2 per Mil-Std-883D method 3015.

3. Electro-optical characteristics (Ta=25°C.)

Parameters	Symbol	Condition	Min.	Typ.	Max.	Unit
Peak wavelength	λ_p	If=150mA	445		455	nm
Dominant wavelength	λ_d	If=150mA	450		460	nm
Radiant output	Wrad	If=150mA	460		540	mW
Luminous output	Lop	If=150mA		6		lm
Radiant efficacy(1) WPE(wall plug efficiency)	Wrad/Pd	If=150mA	40	45		%
Forward voltage	Vf	If=150mA	3.1		3.4	V
Spectral line width	$\Delta\lambda_{1/2}$	If=150mA		20		nm
Viewing angle FWHM	$2\theta_{1/2}$	If=150mA		130		deg
Thermal resistance junction to solder pad	Rthj-s			12		°C/W
Reverse voltage	Vr	If=10uA		0.6		V
Temperature coefficient λ_d	TC λ_d	If=150mA		0.08	0.15	nm/°C
Temperature coefficient Vf	TCv	If=150mA		-3		mV/°C

(1) Radiated efficacy or wall plug efficiency(WPE) is the ratio of total integrated blue power divided by the power dissipated(Wrad/Pd). This is expressed as a percentage of input power.

(2) Parameters are measured by CAS-140 of Instrument System CO.,LTD.

(3) Measurement accuracy : λ (±1nm), Wrad(±10%), Vf(±0.05V).

4. Ranks

Item	Symbol	Rank	Min.	Typ.	Max.	Condition	Unit
Radiant Power	Po	A	160	-	180	IF=150mA	mW
		B	180	-	200		
		C	200	-	220		
		D	220	-	240		
Forward Voltage	Vf	1	3.1	-	3.2		V
		2	3.2	-	3.3		
		3	3.3	-	3.4		
Dominant Wavelength	λ_d	W	450		452.5		nm
		X	452.5		450		
		Y	450		457.5		
		Z	457.5		460		

(1) Parameters are measured by CAS-140 of Instrument System CO.,LTD.

(2) Measurement accuracy : $\lambda(\pm 1\text{nm})$, $W_{rad}(\pm 10\%)$, $V_f(\pm 0.05\text{V})$.

LUMENS

5. Characteristic Graphs(Ta=25°C)

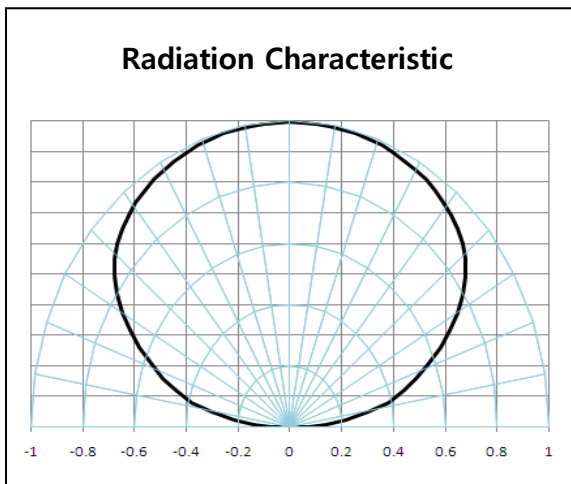
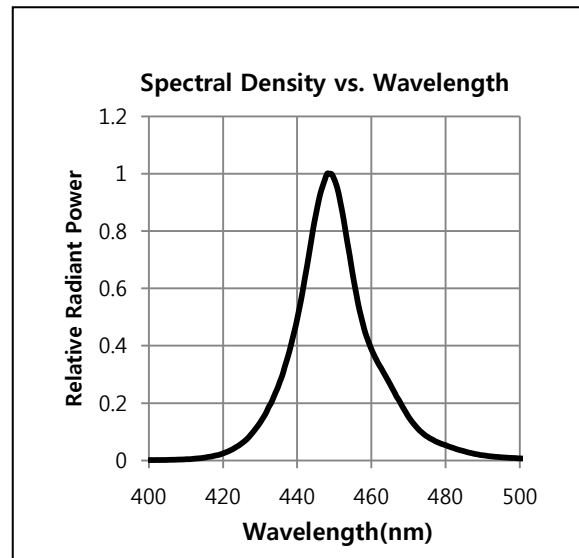
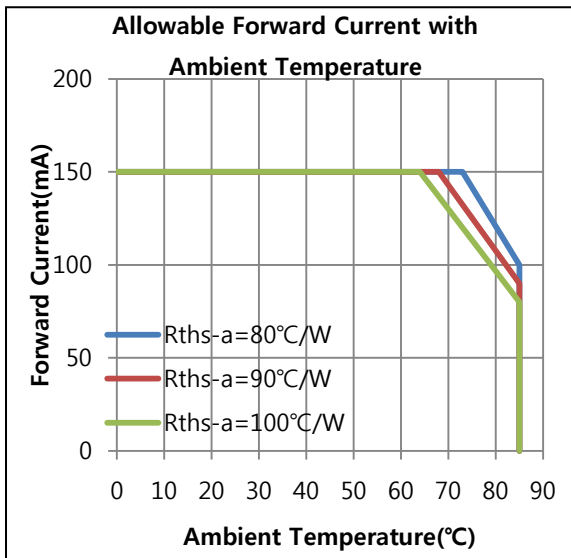
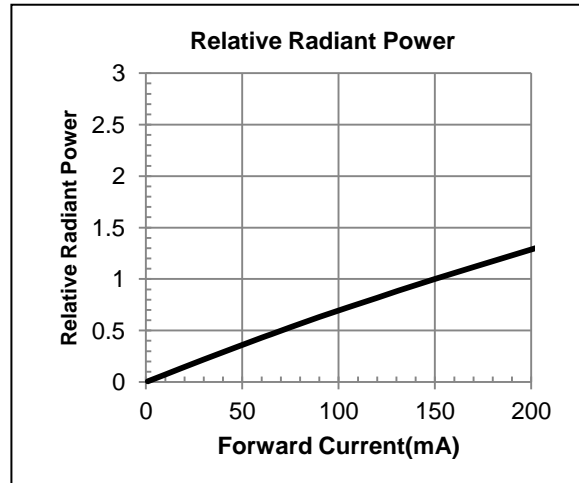
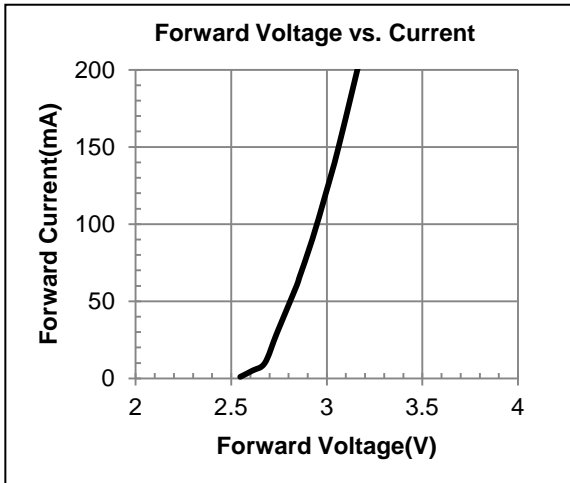

6. Outline Dimensions

Unit : mm

Package outline : (LxWxH) of 3.5 x 3.5 x 2.0 mm.

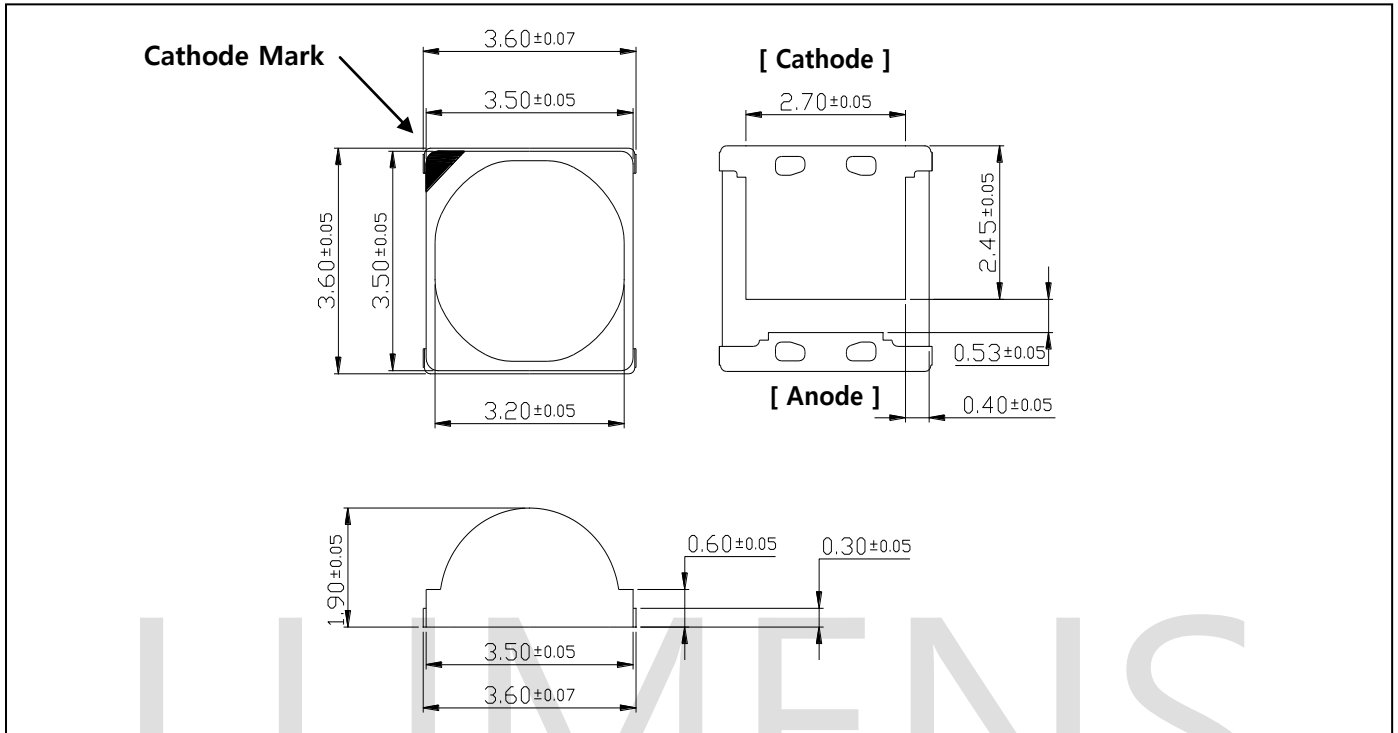

7. Recommended solder pad

(unit : mm)

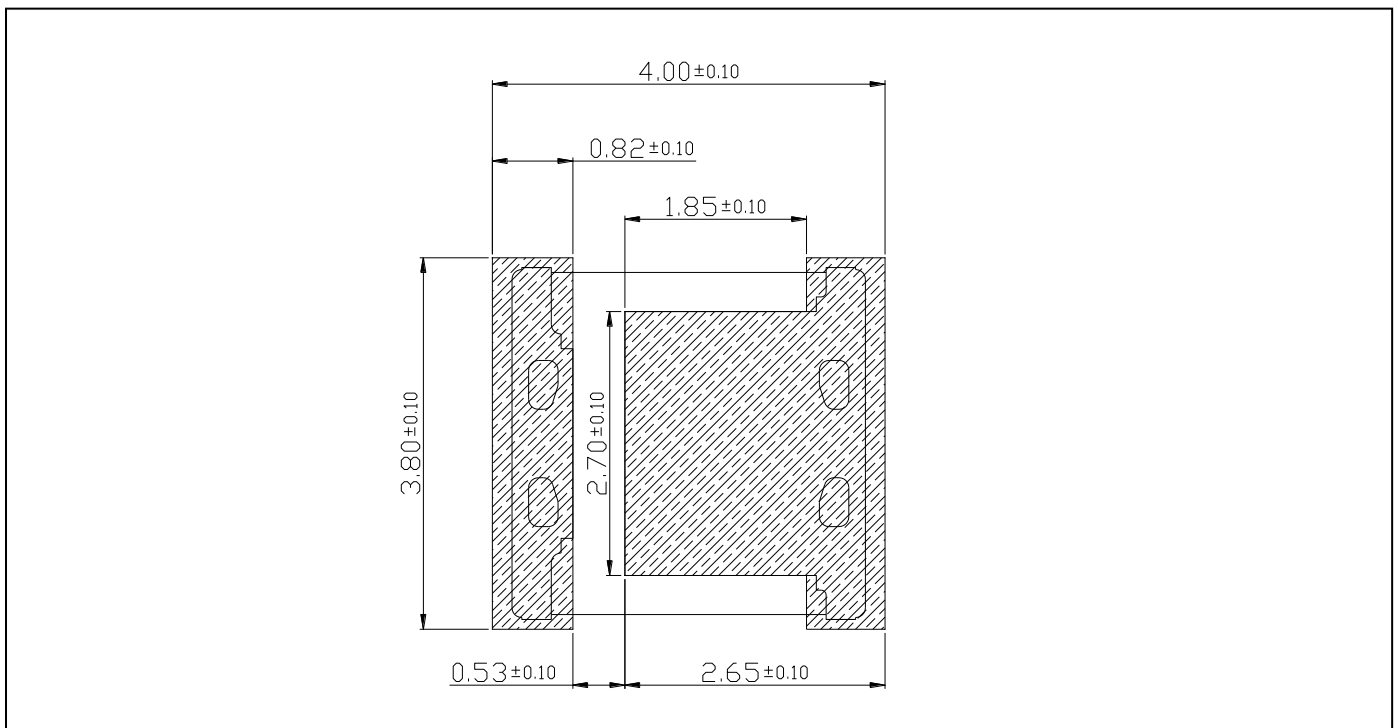

8. Reliability test items and conditions

Item	Reference	Test Conditions	Duration / Cycle	Number of Damaged
Thermal Shock	EIAJ ED-4701	Ta = -40°C (30min) ~ 100°C (30min)	150 Cycle	0/30
Operating Endurance Test	Internal Reference	Ta = 25°C, IF = 150mA	1,000 Hours	0/30
High Temperature High Humidity Life Test	Internal Reference	Ta = 60°C, RH=90%, IF = 150mA	500 Hours	0/30
High Temperature Life Test	Internal Reference	Ta = 85°C, IF = 90mA	500 Hours	0/30
ESD(HBM)		±5KV at 1.5kΩ, 100pF	5 Time	0/5
Reflow	Tsor	260°C < 10sec, Reflow Soldering	3 Time	0/30

- Test Board : Metal board thickness=1.6mm, Copper layer thickness=0.07mm, Rth ≈100 °C/W

◆ CRITERIA FOR JUDGING THE DAMAGE

Item	Symbol	Condition	Criteria for Judgment	
			MIN	MAX
Forward Voltage	VF	IF = 150mA	-	USL (1) × 1.1
Luminous Intensity	IV	IF = 150mA	LSL (2) × 0.7	-

(1) USL : Upper Standard Level

(2) LSL : Lower Standard Level

9. Recommended soldering temperature – time profile for reflow soldering

Surface Mounting Condition

In automatic mounting of the SMD LEDs on printed circuit boards, any bending, expanding and pulling forces or shock against the SMD LEDs should be kept minimum to prevent them from electrical failures and mechanical damages of the devices.

Soldering Reflow

- Soldering of the SMD LEDs should conform to the soldering condition in the individual specifications.
- SMD LEDs are designed for reflow soldering.
- In the reflow soldering, too high temperature and too large temperature gradient such as rapid heating/cooling may cause electrical & optical failures and damages of the devices.
- Lumens cannot guarantee the LEDs after they have been assembled using the solder dipping method.

Recommended Pb Free IR-Reflow Soldering Profile.

Classification Reflow Profile (JEDEC J-STD-020C)

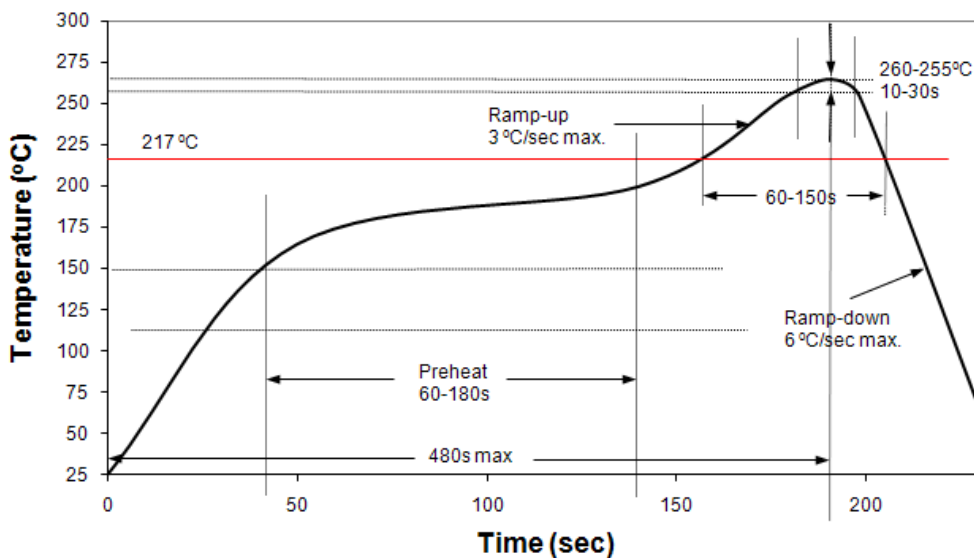

10. Taping and orientation

1. Moisture proof bag.
2. 1 Reel/bag.
3. Q'ty: 800(MAX)/Reel.

<Carrier tape Dimension>

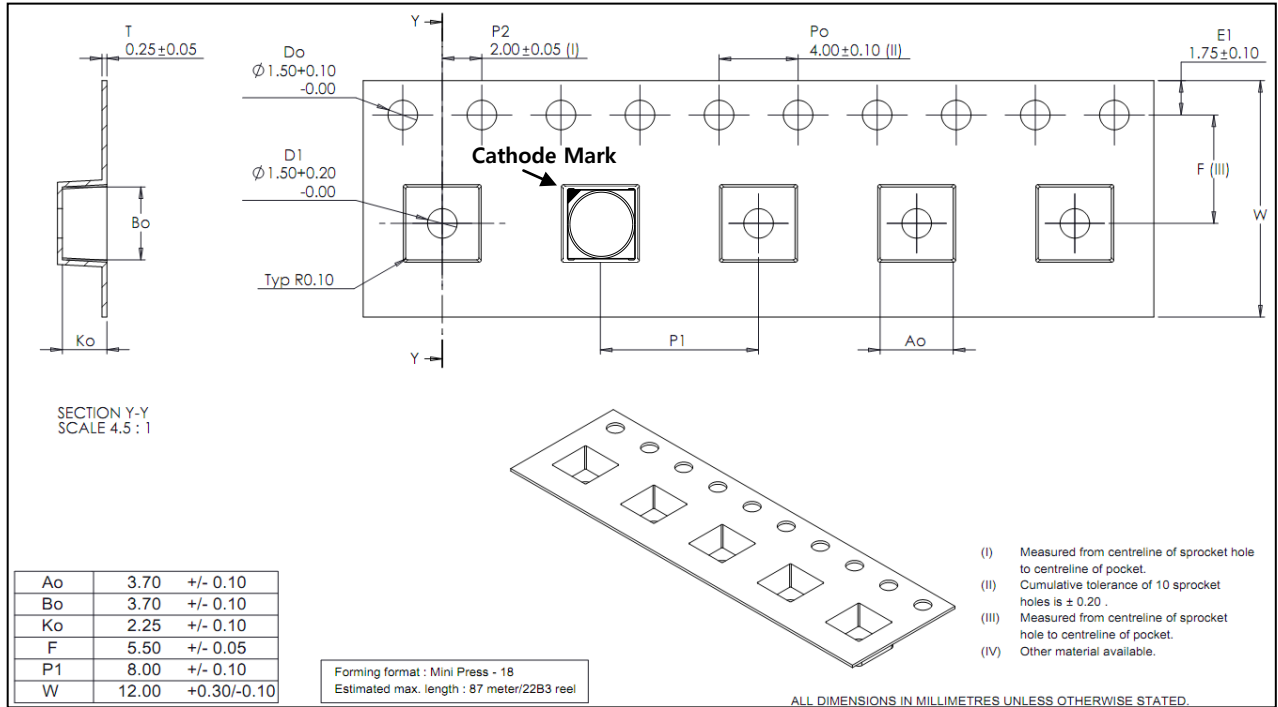

<Reel Dimension>

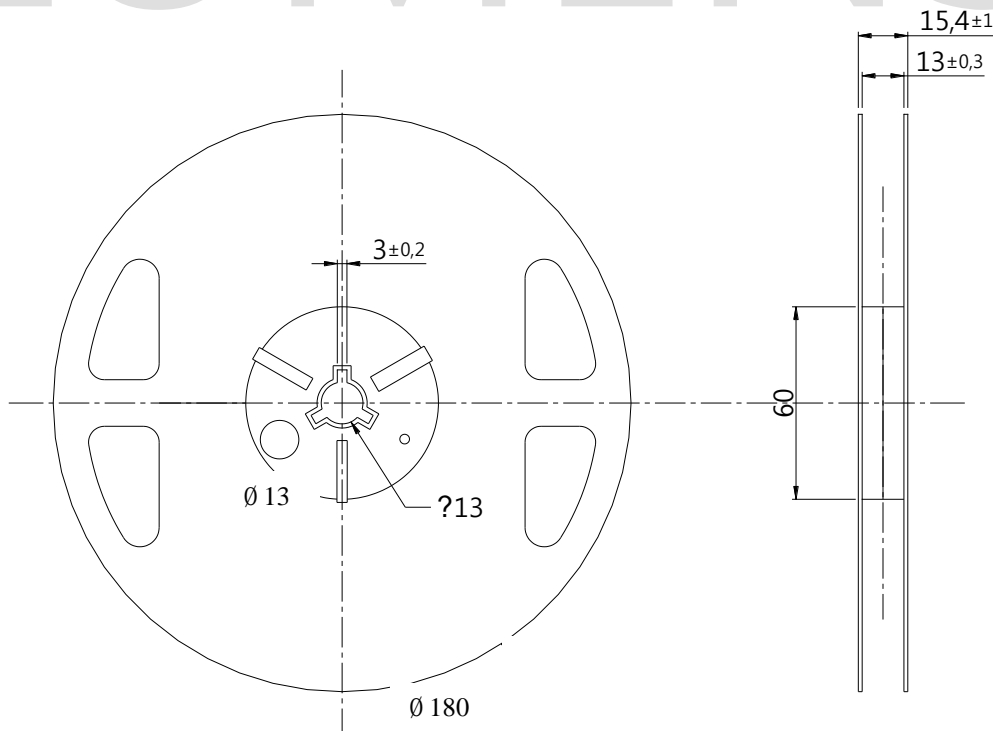

11. Cautions

- 1 Moisture-Proof Package
 - 1.1 When moisture is absorbed into the LED package it may vaporize and expand products during soldering. There is a possibility that this may cause exfoliation of the contacts and damage to the optical characteristics of the LEDs. For this reason, the moisture-proof package is used to keep moisture to a minimum in the package.
 - 1.2 A package of a moisture-absorbent material (silica gel) is inserted into the shielding bag. The silica gel changes its color from blue to pink as it absorbs moisture.
- 2 Current limiting

A resistor should be used to limit current spikes that can be caused by voltage fluctuations. Otherwise damage could occur.
- 3 Iron Soldering
 - 3.1 Hand soldering is not recommended for regular production. These guidelines are for rework only.
 - 3.2 Soldering iron tip should contact each terminal no more than 3 sec at 350°C, using soldering iron with nominal power less than 25W. Allow min. 2 sec. between soldering intervals.
- 4 Storage Conditions
 - 4.1 Before opening the package: The LEDs should be kept at 30°C or less and 90%RH or less. The LEDs should be used within a year. When storing the LEDs, moisture-proof packaging with moisture-absorbent material (silica gel) is recommended.
 - 4.2 After opening the package: The LEDs should be kept at 30°C or less and 70%RH or less. The LEDs should be soldered within 168 hours (7 days) after opening the package. If unused LEDs remain, they should be stored in moisture-proof packages, such as sealed containers with packages of moisture-absorbent material (silica gel). It is also recommended to return the LEDs to the original moisture-proof bag and to reseal the moisture-proof bag again.
 - 4.3 If the moisture-absorbent material (silica gel) has faded away or the LEDs have exceeded the recommended storage time, baking treatment should be performed using the following conditions. Baking treatment: more than 24 hours at 65±5°C
 - 4.4 Lumens LED electrode sections are comprised of a silver-plated copper alloy. The silver surface may be affected by environments which contain corrosive gases and so on. Please avoid condition which may cause difficulty environments during soldering operations. It is recommended that the user uses the LEDs as soon as possible.
 - 4.5 Please avoid rapid transitions in ambient temperature, especially in high humidity environments where condensation can occur.
- 5 Handling of Silicone Lens LEDs
 - 5.1 Avoid silicone resin parts especially with sharp tools such as pincette(tweezers).
 - 5.2 Avoid leaving fingerprints on silicone lens part.
 - 5.3 Do not apply the silicone lens part with pressure especially in SMT production. So use a proper nozzle not to press the lens part of the LED to pick and place.
- 6 Usage
 - 6.1 Do not exceed the values given in this specification.

NOTE :

All the information published is considered to be reliable. However, Lumens does not assume any liability arising out of the application or use of any product described herein.

Lumens reserves the right to make changes at any time without notice to any products in order to improve reliability, function or design.

Lumens products are not authorized for use as critical components in life support devices or systems without the express written approval from the managing director of Lumens.